

KLINGER®-KGS

Rubber- Metal-Gasket

Where safe sealing of water, air, acids, alkalines and hydrocarbons is required at low forces and low temperatures, KLINGER-KGS is an interesting solution.

Suitable for flanges made of plain steel, stainless steel, glassfibre reinforced plastic, PP, PVC, PE and for coated flanges.

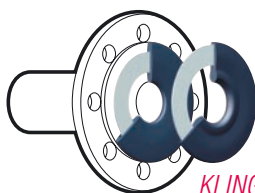

KLINGER – The worldwide leader in seal technology



KGS

GAS

CHEMISTRY



WATER

WASTE WATER

KLINGER-KGS

Rubber-Metal-Gasket

KLINGER-KGS
Rubber-Metal-Gasket
acc. to DIN EN 1514-1,
Form IBC
replaces DIN 2690

Application fields

Media

- water
- gas
- waste water
- chemicals

Flanges

- plain steel, stainless steel
- cast iron
- GFK (glassfibre reinforced plastic)
- PP/ PVC/ PE
- coated flanges

Safe sealing of water, air, acids, caustic solutions and hydrocarbons with low forces at temperatures up to max. 200°C.

Type KGS, Typ KGS/Guss*

- at piping design for gas and water piping
- for slightly damaged and not always correct routed pipelines

Type KGS/S

- at piping design for gas and water piping
- at rubber coated flanges of pipes and apparatus
- at enamelled flanges of pipes and apparatus
- fat constructions of plastic apparatus (low sealing forces)

* for cast iron flange dimensions

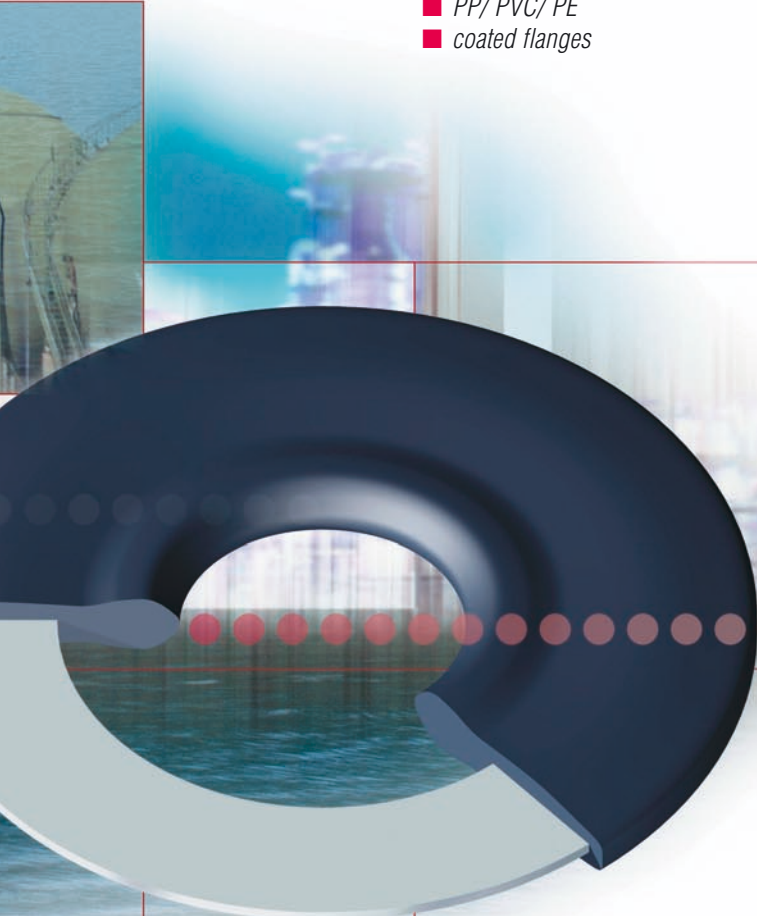

KGS/S

Characteristic values for NBR-GW and EPDM-KTW

$$k_0 \times K_D = 2 \text{ b (N/mm}^2\text{)}$$

$$k_1 = 0.5 \text{ (mm)}$$

Max. roughness:
 50 bis 100 μm
 depending on roughness.

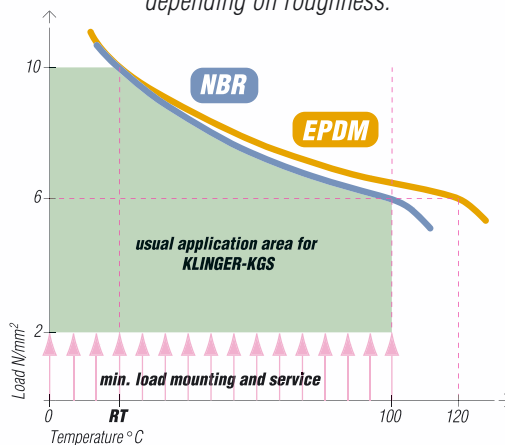

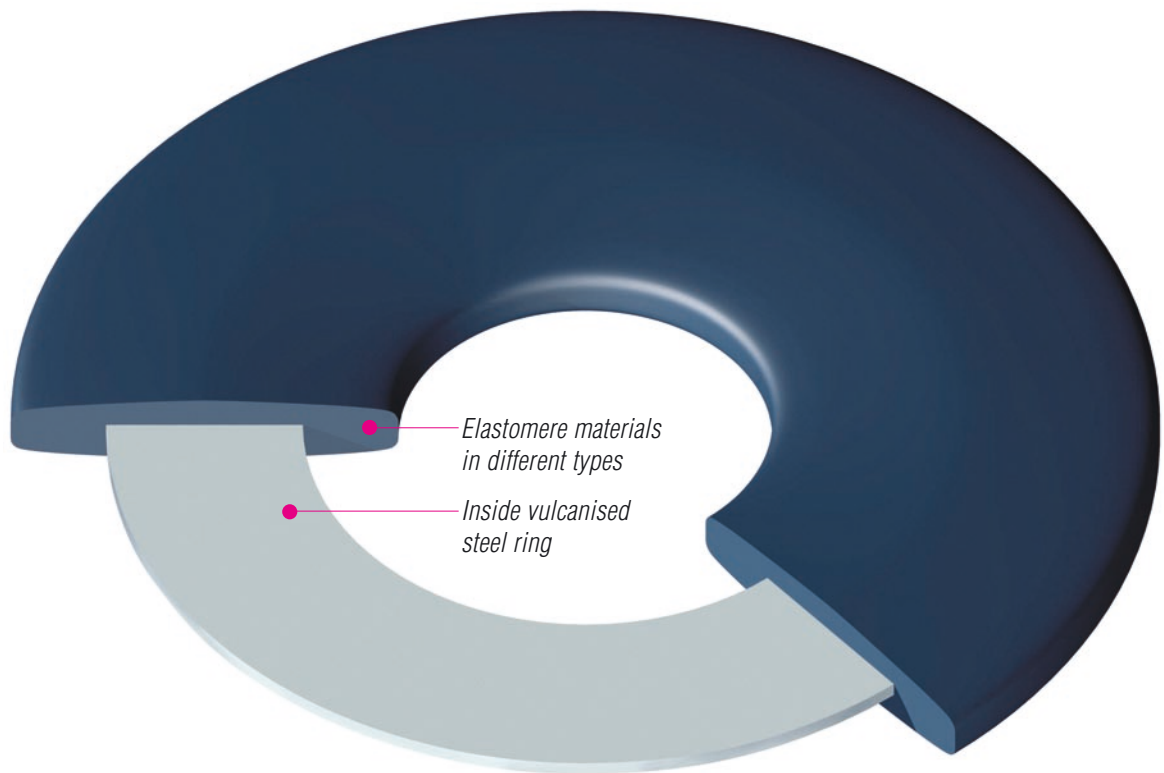

KGS and KGS/Guss*

- *Vulcanised rubber gasket, lenticular shape, rounded edges.*
- *Inside vulcanised steel ring, thereby good absorption of surface pressure.*
- *Outer diameter self-centering to the inner diameter of the screw holes.*

■ *The gaskets are made of NR = Vulcanisates of natural rubber (SBR), NBR-GW (Nitril rubber), EPDM-KTW (Ethylen-Propylen rubber), CSM/ Hypalon (chlorosulfonated polyethylene) and FKM = Viton (Fluoro elastomere) every with inside vulcanised steel ring.*

■ *The NBR-GW-type is approved by DVGW and recommended according to KTW (potable water application).*

■ *Dimension in DIN EN 1514-1 (replaces DIN 2690) for the pressure ratings PN 6 to PN 40.*

*Example for order:
Rubber-Metal-Gasket KLINGER-KGS
made of NBR-GW according to
DIN EN 1514-1, Form IBC
DN 100, PN 10-16*

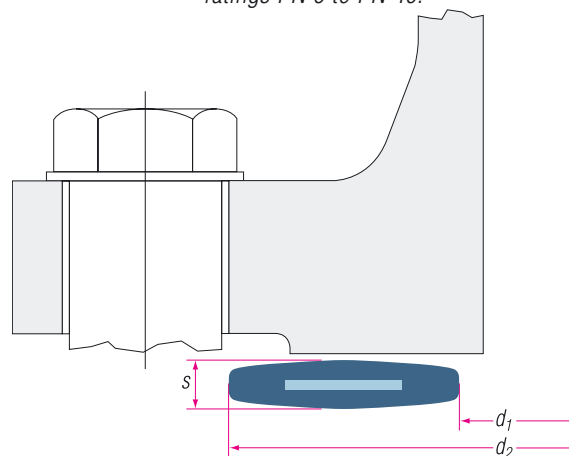

Sizes at the measurement table

- s = Thickness*
- d₁ = Inner diameter*
- d₂ = Outer diameter*

** for cast iron
flange dimensions*

KLINGER-KGS Rubber-Metal-Gasket

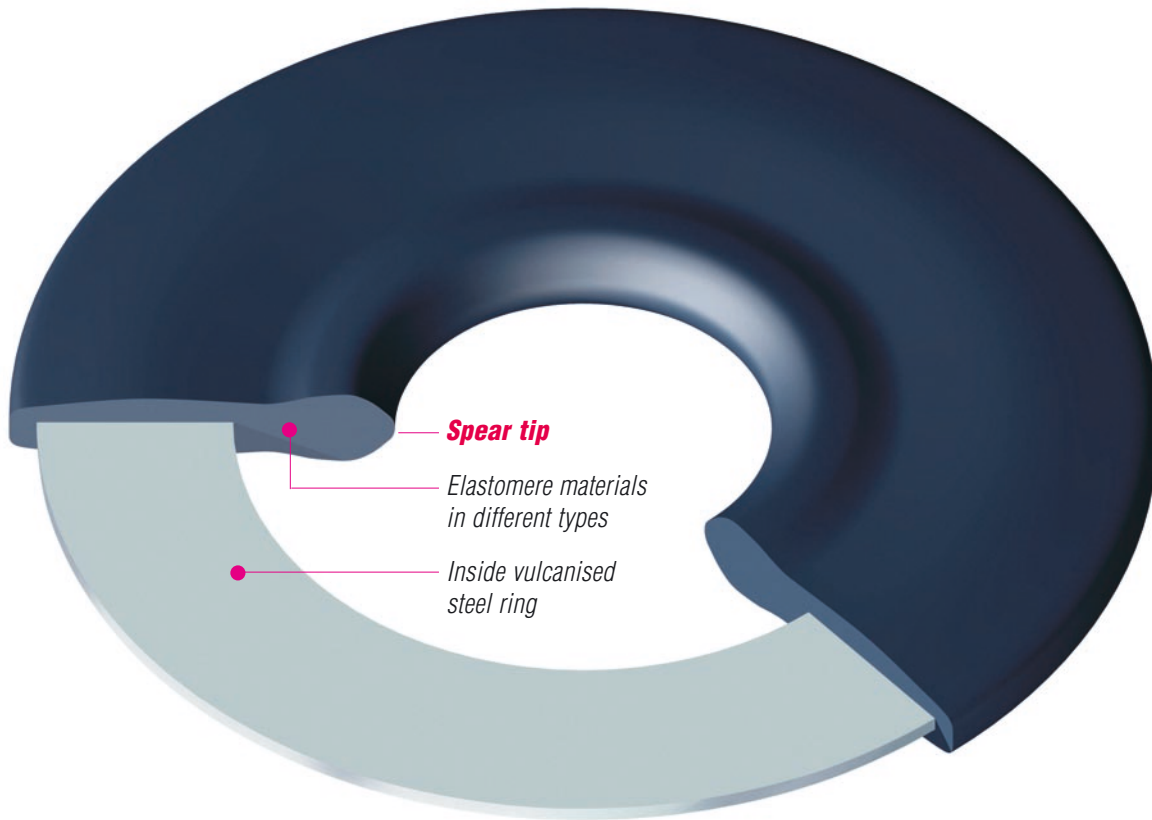

KGS/S (S = Spear tip)

■ Vulcanised rubber gasket, lenticular shape at the gasket body with integrally molded **spear tip** at the inside of the gasket, rounded edges. The new shape with "**spear tip**" offers higher safety against pressurized volumes at the sealing area and corrosion.

■ Thereby especially suitable for flanges made of thermoplastic material.

■ Optimal sealing properties in case of flange unevennesses.

■ Safe sealing already at lowest tightening torques.

■ The gaskets are made of NR = Vulcanisates of natural rubber (SBR), NBR-GW (Nitril rubber), EPDM-KTW (Ethylen-Propylen rubber), CSM/ Hypalon (chlorosulfonated polyethylene) and FKM = Viton (Fluoro elastomere) every with inside vulcanised steel ring.

■ The NBR-GW-type is approved by DVGW and recommended according to KTW (potable water application).

■ Dimension in DIN EN 1514-1 (replaces DIN 2690) for the pressure ratings PN 6 to PN 40.

Example for order:
Rubber-Metal-Gasket KLINGER-KGS
made of NBR-GW according to
DIN EN 1514-1, Form IBC
DN 100, PN 10-16

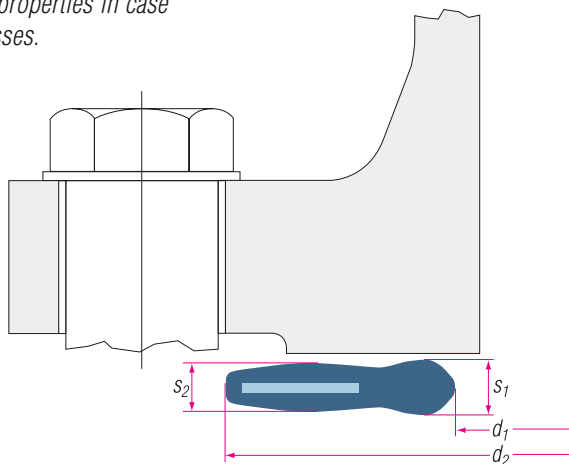

Sizes at the measurement table

s_1 = Sealing lip
 s_2 = Sealing body
 d_1 = Inner diameter
 d_2 = Outer diameter



Material

NR

NBR-GW

Function and durability

The performance and life of KLINGER gaskets depend in large measure on proper storage and fitting, factors beyond the manufacturer's control. We can, however, vouch for the excellent quality of our products. With this in mind, please also observe our installation instructions.

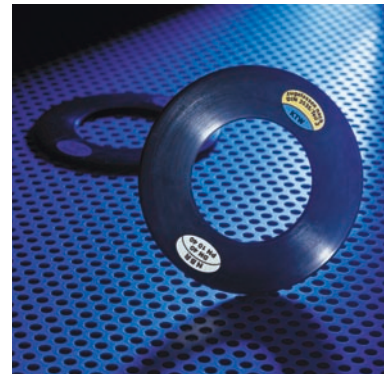
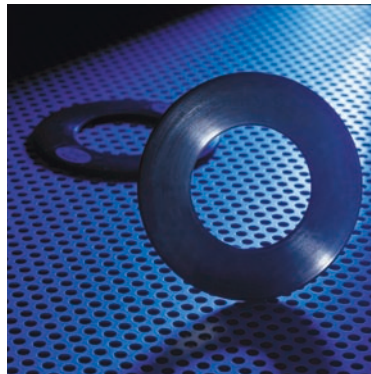

Application field

NR = Natural rubber (SBR) for water, closed loop water arrangements, soluted lyes at max. 50 % conc. and max. 80°C

Gas and potable water. Approved according to pr EN682 (DIN E 3535T3) approved according to KTW D1/D2, 1.3.31 of national health service

Colour

black

black

Hardness

DIN 53505, Shore A 60 - 80 ±5

DIN 53505, Shore A 70 ±5

Density

DIN 53479, g/cm³ 1,384

DIN 53479, g/cm³ 1,196

Temperature

approx +80°C, short-term up to +90°C

app. +100°C, short-term up to +130°C

Certificates

Approval of own test facility

DVGW-approval incl. KTW-approval

Chemical resistance

Resistant against:

- water, seawater, pond water, closed loop water up to 90°C
- partly against alkalines, 50% NaOH at 50°C
- sufficient resistant against natural lighting, weather and ozone

Resistant against:

- aliphatic hydrocarbons (mineral oils and greases, diesel fuel, petrol)
- many of diluted acids and alkalines at ambient temperature
- water and many salt dilutions at ambient temperature
- animal and vegetable oils and greases

Not resistant against:

- fuel, mineral oils, acids and gases

Not resistant against:

- aromatic and chlorinated hydrocarbons
- highly oxidising acids
- polar solvents

Application

The application of NR-vulcanisates is possible where natural media have to be sealed. Temperatures higher than 90°C have to be avoided.

The NBR type has a good chemical resistance against aliphatic hydrocarbons, mineral oils and greases, diesel fuel and petrol.

KLINGER Rubber-Metal-Gasket Type KGS, KGS/Guss*, KGS/S

EPDM-KTW

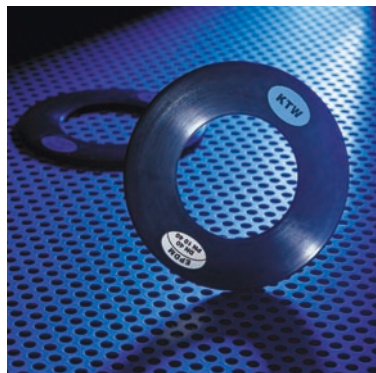

Potable water/ waste water.
Approved according to KTW D1/D2,
1.3.31 of national health service
for potable water

black

DIN 53505, Shore A 70 ±5

DIN 53479, g/cm³ 1,120

app. +100°C, short-term up to +130°C

KTW-approval, EN 681-1,
W 270, ACS, WRC, Ö-Norm

Resistant against:

- water and water dilutions of salts
- many of diluted acids and alkalines
- polar media as alcohol, ester and ketone
- washing agents
- hydraulic media based on water-glycol (HFC-fluids)
- hydraulic media based on phosphoric esters (HFD-R-fluids)

Not resistant against:

- aliphatic, aromatic and chlorinated hydrocarbons (oils, greases and fuels)
- highly oxidising acids

Additionally to the applications acc. to the chemical resistance, the EPDM type is well suitable for applications which require good ozone-, ageing- and weathering resistance.

CSM

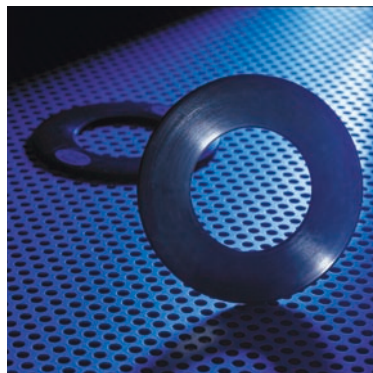

CSM / Hypalon
(chlorosulfonated polyethylene)
the application are in the chemical
industry

black

DIN 53505, Shore A 70 +/-5

DIN 53479, g/cm³ 1,340

approx. +80°C

Approval of own test facility

Resistant against:

- many acids up to 50°C
- good resistant against natural lighting and ozone

Not resistant against:

- at temperatures below -15°C and over +80°C

The application of CSM-vulcanisates are in the chemical industry, dry-cleaning etc.

FKM/Viton

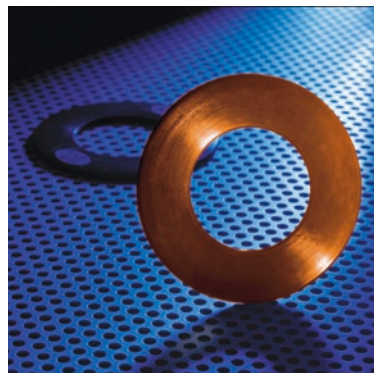

FKM= Viton (Fluoro elastomere)
the application are in the chemical
industry and production

brown

DIN 53505, Shore A 75 +/-5

DIN 53479, g/cm³ 1,880

approx. +200°C

Approval of own test facility

Resistant against:

- acids and alkalines
- gases
- all kind of water

Not resistant against:

- partial resistance at temperatures of -10°C and lower

As there is a good chemical resistance for acids and alkalines, the main application field is in the chemical production and users of chemicals.

* for cast iron
flange dimensions





Type KGS and KGS/Guss*



* for cast iron flange dimensions

Type KGS/S

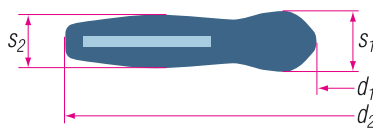

Sizes at the measurement table

s = Thickness
 s_1 = Sealing lip
 s_2 = Sealing body
 d_1 = Inner diameter
 d_2 = Outer diameter

Dimension in DIN EN 1514-1
 (replaces DIN 2690) for the pressure
 ratings PN 6 to PN 40.

The gaskets are made of
 NR = Vulcanisates of natural rubber
 (SBR), NBR-GW (Nitril rubber),
 EPDM-KTW (Ethylene-Propylene
 rubber), CSM/ Hypalon (chlorosul-
 fonated polyethylene) and FKM =
 Viton (Fluoro elastomere) every with
 inside vulcanised steel ring.

Example for order:
 Rubber-Metal-Gasket KLINGER-KGS
 made of NBR-GW according to
 DIN EN 1514-1, Form IBC
 DN 500, PN 10

The table on the right is only for your
 information. Please refer to our
 actual price list to find those dimen-
 sions which can be delivered or give
 us your inquiry.

DN	s Type KGS	s Type KGS/S	d ₁ DIN 2690	d ₁ DIN 1514	1 / 2,5 DIN 2690	1 / 2,5 DIN 1514
4	–	–	6	–	–	–
6	–	–	10	–	28	–
8	–	–	14	–	33	–
10	–	–	18	18	38	39
15	4	3 / 4	22	22	43	44
20	4	3 / 4	28	27	53	54
25	4	3 / 4	35	34	63	64
32	4	3 / 4	43	43	75	76
40	4	3 / 4	49	49	85	86
50	4	4 / 5	61	61	95	96
60 ¹	–	–	–	–	–	106
65	4	4 / 5	77	77	115	116
80	4	4 / 5	90	89	132	132
100	5	5 / 6	115	115	152	152
125	6	5 / 6	141	141	182	182
150	6	6 / 7	169	169	207	207
(175)	–	–	195	–	237	–
200	6	6 / 7	220	220	262	262
250	6	6 / 7	274	273	318	317
300	6	6 / 7	325	324	373	373
350	7	7 / 9	368	356	423	423
400	7	7 / 9	420	407	473	473
450	7	7 / 9	470	458	528	528
500	7	7 / 9	520	508	578	578
600	7	7 / 9	620	610	680	679
700	8	8 / 10	720	712	785	784
800	8	8 / 10	820	813	890	890
900	8	8 / 10	920	915	990	990
1000	8	8 / 10	1020	1016	1090	1090
1100	8	8 / 10	–	1120	–	–
1200	8	8 / 10	1220	1220	1290	1290
1400	8	8 / 10	1420	1420	1490	1490
1500 ¹	–	–	–	1520	–	–
1600	8	8 / 10	1620	1620	1700	1700
1800	8	8 / 10	1820	1820	1900	1900
2000	8	8 / 10	2020	2020	2100	2100
2200	–	–	2220	2220	2305	2307
2400	–	–	2420	2420	2505	2507
2600	–	–	2620	2620	2705	2707
2800	–	–	2820	2820	2920	2924
3000	–	–	3020	3020	3120	3124
3200	–	–	3220	3220	3320	3324
3400	–	–	3420	3420	3520	3524
3600	–	–	3620	3620	3730	3734
3800	–	–	3820	3820	3930	3931
4000	–	–	4020	4020	4130	4131

Dimensions in mm, 1) only for cast iron flanges



Medium	NR	NBR-GW	EPDM-KTW	CSM	FKM-Viton
Acetaldehyde	●	▲	●	■	▲
Acetamide	▲	●	●	■	■
Acetic acid	■	▲	●	▲	▲
Acetic acid ester	▲	▲	●	●	▲
Acetone	●	▲	●	■	▲
Acetylene	●	●	●	●	●
Adipic acid	●	●	●	●	●
Air	▲	▲	●	■	●
Alum	●	●	●	●	●
Aluminium acetate	●	●	●	■	▲
Aluminium chloride		●	●		
Aluminium phthalate	●	●	●	●	●
Ammonia	■	■	●	●	▲
Ammonium carbonate	●	■	●	●	■
Ammonium chloride	●	●	●	●	■
Ammonium diphosphate		●	●		
Ammonium hydroxide	■	■	●	●	■
Amyl acetate	■	▲	●	▲	▲
Aniline	■	▲	●	▲	●
Anon cyclohexanone	▲	▲	■	▲	▲
Arcton 12	■	●	■	■	●
Arcton 22	●	▲	●	●	▲
Asphalt	▲	▲	▲	▲	●
Aviation fuel	▲	●	▲	▲	●
Barium chloride	●	●	●	●	●
Benzene	▲	▲	▲	▲	●
Benzoic acid	●	●	●	●	●
Blast furnace gas	▲	▲	▲	▲	■
Bleaching solution	▲	▲	●	●	●
Boiler feed water	▲	■	●	▲	■
Borax	●	●	●	●	●
Boric acid	●	●	●	●	●
Brine		●	●	●	●
Butane	▲	●	▲	■	●
Butanol	●	■	●	●	●
Butanone	▲	▲	●	■	▲
Butyl acetate	▲	▲	●	▲	▲
Butylamine	▲	●	▲	▲	▲
Butyle alcohol	●	■	●	●	●
Butyric acid	▲	▲	●	▲	■
Caesium melt	▲	▲	▲	▲	▲
Calcium chloride	●	●	●	●	●
Calcium hydroxide	●	●	●	●	●
Calcium hypochlorit	▲	▲	●	●	●
Calcium sulphate		●	●		
Carbolic acid	▲	▲	■	▲	●
Carbon dioxide	●	●	●	●	●
Carbon disulphide	▲	▲	▲	▲	●
Carbon tetrachlorid	▲	▲	▲	▲	●
Castor oil	●	●	●	●	●
Chlorine water	▲	▲	■	▲	●
Chlorine, dry	▲	▲	■	▲	●
Chlorine, moist	▲	▲	■	▲	●
Chloroform	▲	▲	▲	▲	●
Chromic acid	▲	▲	■	■	●

Medium	NR	NBR-GW	EPDM-KTW	CSM	FKM-Viton
Citric acid	●	●	●	●	●
Clorotrifluoride	▲	▲	▲	▲	▲
Condensation water	▲	●	●	▲	■
Copper acetate	■	■	●	■	▲
Copper sulphate	●	●	●	●	●
Creosote	▲	▲	■	■	●
Cresol	▲	▲	▲	▲	●
Crude oil	▲	●	▲	■	●
Cyclohexanol	▲	●	▲	■	●
Decahydronaphthalen	▲	■	▲	▲	●
Dibenzyl ether	▲	▲	■	▲	●
Dibutyl phthalate	▲	▲	●	▲	■
Diesel oil	▲	●	▲	▲	●
Dimethyl formamide	▲	▲	●	▲	▲
Diphyl	▲	▲	▲	▲	●
Ethane	▲	●	▲	■	●
Ethanol	●	■	●	●	●
Ethyl acetate	▲	▲	●	▲	▲
Ethyl alcohol	●	■	●	▲	●
Ethyl chloride	▲	■	■	▲	●
Ethyl ether	▲	▲	▲	▲	▲
Ethylendiamine	●	●	●	■	▲
Ethylene	▲	●	▲	▲	▲
Ethylene chloride	▲	▲	▲	▲	●
Ethylene glycol	●	●	●	●	●
Fluorine dioxide		▲	▲		
Fluorine gaseous		▲	▲		
Fluorine liquid	▲	▲	▲	▲	■
Fluorosilicic acid	▲	▲	▲	▲	■
Formaldehyde	●	●	●	●	■
Formamide	●	▲	●	●	■
Formic acid 10%	■	▲	●	●	▲
Freon 12	■	●	■	●	■
Freon 22	■	▲	●	●	▲
Generator gas		●	▲		●
Glacial acetic acid	■	▲	●	▲	▲
Glycerin	●	●	●	●	●
Heating oil	▲	●	▲	▲	●
Heptane	▲	●	▲	▲	●
Hydraulic oil (mineral)	▲	●	▲	▲	●
Hydraulic oil (phosphat ester)	▲	▲	●	▲	●
Hydrazine hydrate	▲	■	●	■	▲
Hydrochloric acid (10%)	■	■	●	●	●
Hydrochloric acid (37%)	▲	▲	●	▲	▲
Hydrofluorid acid	▲	▲	●	●	●
Hydrofluosilic acid	●	●	●	●	●
Hydrogen	●	●	●	●	●
Hydrogen chloride (dry)	■	▲	●	●	●
Hydrogen peroxide 3%	■	■	●	●	●
Hydrogen peroxide 90%	▲	▲	▲	▲	●
Hydrogen sulfide	▲	▲	●	▲	▲
Isooctane	▲	●	▲	■	●
Isopropyl alcohol	●	■	●	●	●
Kerosene	▲	●	▲	▲	●
Lactic acid	●	●	●	●	●

● Resistant
 ■ Condit. recommended
 ▲ Not recommended

KLINGER-KGS

Chemical resistance

Medium	NR	NBR-GW	EPDM-KTW	CSM	FKM-Viton
Lead acetate	●	■	●	▲	▲
Lead arsenate		●	●		
Linseed oil	■	●	■	■	●
Lithium melt	▲	▲	▲	▲	▲
Magnesium sulphate	●	●	●	●	●
Malic acid	▲	●	●	●	●
MEK butanone	▲	▲	●	■	▲
Methane	▲	●	▲	■	●
Methyl alcohol	●	■	●	●	▲
Methyl chloride	▲	▲	▲	▲	●
Methylene chloride	▲	▲	▲	▲	■
Mineral oil	▲	●	▲	■	●
Monochlorethane	▲	▲	▲	▲	●
Naphtha	▲	▲	▲	▲	■
Natural gas	▲	●	▲	■	●
Nitric acid	▲	▲	▲	▲	●
Nitrobenzene	▲	▲	■	▲	●
Nitrogen	●	●	●	●	●
Octane (n)	▲	■	▲	▲	●
Oil	■	●	▲	■	●
Oleanolic Acid	▲	▲	▲	■	●
Oleic acid	▲	■	▲	▲	●
Oxalic acid	■	■	●	■	●
Oxygen, gaseous, cold	▲	■	●	■	●
Palmitic acid	■	●	■	■	●
Patable water	●	●	●	●	●
Pentane	▲	●	▲	■	●
Perchloroethylene	▲	▲	▲	▲	●
Petroleum	▲	●	▲	▲	●
Petroleum benzin	▲	■	▲	■	●
Petroleum ether	▲	●	▲	▲	●
Phenol	▲	▲	■	▲	●
Phosphoric acid	▲	▲	■	▲	●
Polychl.biphenyls.	▲	▲	▲	▲	●
Potass.chrom.sulph.		■	●		●
Potassium acetate	●	■	●	▲	▲
Potassium carbonate	●	●	●	●	●
Potassium chlorate	■	▲	●	●	●
Potassium chloride	●	●	●	●	●
Potassium cyanide	▲	■	●	●	●
Potassium cyanide	●	●	●	●	●
Potassium dichrom.	■	■	●	●	●
Potassium hydroxide	■	■	●	●	▲
Potassium hypochl.		▲	■		
Potassium iodide	●	●	●	●	●
Potassium melt	▲	▲	▲	▲	▲
Potassium nitrate	▲	●	●	●	■
Potassium nitrite	●	●	●	●	●
Potassium permang.	▲	▲	●	●	●
Propane	▲	●	▲	■	●
Pydraul C	▲	▲	▲	▲	●
Pydraul E	▲	▲	■	▲	●
Pyridine	▲	▲	■	▲	▲
Rape seed oil	▲	●	■	■	●
Rubidium melt	▲	▲	▲	▲	▲

Medium	NR	NBR-GW	EPDM-KTW	CSM	FKM-Viton
Salicylic acid	●	●	●	●	●
Sea water	●	●	●	●	■
Silicon oil	●	●	●	●	●
Skydrol 500, 7000	▲	▲	●	▲	■
Soap, solution	■	●	●	●	●
Soda	●	●	●	●	●
Sodium aluminate		▲	■		
Sodium bicarbonate	●	●	●	●	●
Sodium bisulphite	■	●	●	●	●
Sodium chloride	●	●	●	●	●
Sodium cyanide	●	●	●	●	●
Sodium hydroxide	■	■	●	●	▲
Sodium melt	▲	▲	▲	▲	▲
Sodium silicate	●	●	●	●	●
Sodium sulfide	■	●	●	●	●
Sodium sulphate	●	●	●	●	●
Spirit	●	■	●	●	●
Starch	●	●	●	●	●
Steam (max. 150 °C)	▲	▲	●	▲	▲
Stearic acid 100°C	▲	▲	▲	■	●
Sugar	●	●	●	●	●
Sulphur dioxide	▲	▲	●	▲	●
Sulphuric acid	▲	▲	▲	▲	●
Sulphurous acid	■	■	●	●	●
Table salt	●	●	●	●	●
Tannic acid	●	●	●	●	●
Tannin	●	●	●	■	●
Tar	▲	▲	▲	▲	●
Tartaric acid	●	●	●	●	●
Tetrachloroethane	▲	▲	▲	▲	■
Tetrahydronaphthale	▲	▲	▲	▲	●
Toluene	▲	▲	▲	▲	●
Town gas (benzene free)	▲	●	▲	■	●
Transformer oil	▲	●	▲	▲	●
Trichloroethylene	▲	▲	▲	▲	●
Triethanolamine	■	▲	■	■	▲
Turpentine	▲	■	▲	▲	●
Urea	●	●	●	●	●
Vinyl acetate	▲	▲	▲	▲	▲
Water 100°C	▲	■	●	▲	■
Water flask	●	●	●	●	●
Water vapour (max. 150°C)	▲	▲	●	▲	▲
White spirit	▲	■	▲	▲	●
Xylene	▲	▲	▲	▲	●

● Resistant
 ■ Condit. recommended
 ▲ Not recommended

On principle following mounting instructions for KLINGER-KGS material have to be taken in account.

1. Selection of the gasket

The suitable type of gasket material can be selected according the KLINGER information – first of all the chemical resistance.

2. The Flanges

Flanges should be parallel, metallically clean and dry, the gasket has to be mounted centrally.

Please pay attention to the correct inner- and outer diameter, never the gaskets should tower into the throughhole!

The outer diameter of the KGS-gasket is adapted to the bolt circle of the flange. Therefore a safe centering is insured by the bolts.

3. The mounting of the gasket

The mounting of the gasket should be performed without any grease- or oil-containing separating media.

On no account oil or grease containing products may be used, as they have a negative influence on the safety of the complete flange connection.

4. The Bolts

During installation the bolts have to be tightened in several steps, equal and crosswise.

The screws should be greased if possible.

5. Re-tighten

"Re-tighten" is usually not necessary if a.m. references will be followed.

6. "Multi-use" of a gasket

To use a gasket more than one time can not be recommended.

If there is an demand on advice please contact a KLINGER company or an representative.

**Klinger supplies you
with superior seal products
for all applications**

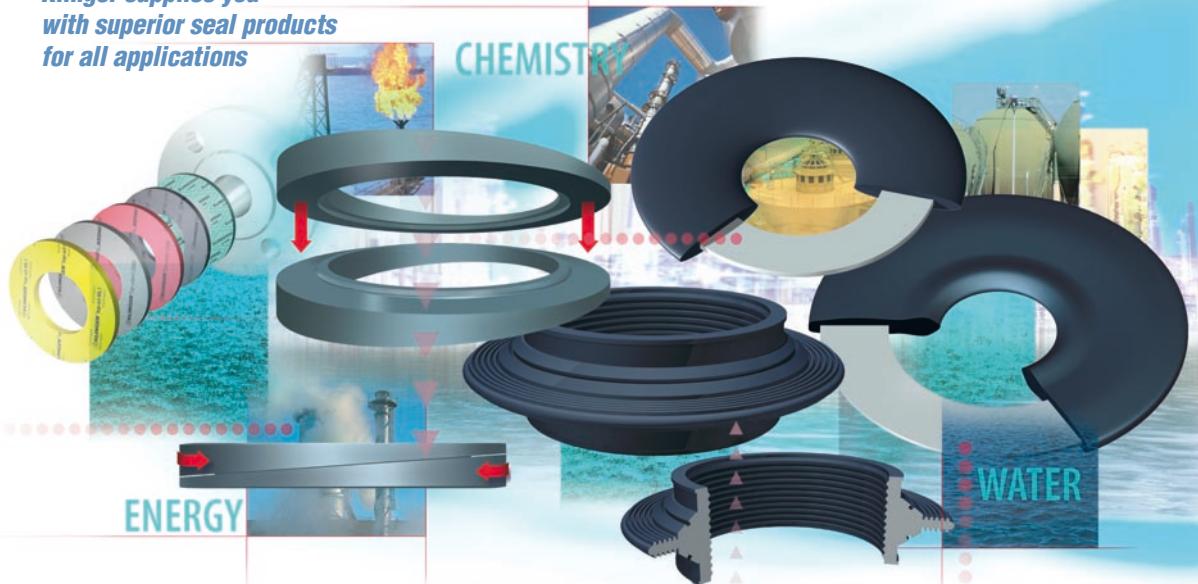

KLINGER Service for your safety:
Application overviews, product documentations, tables for media resistance, safety service by fax, original test material and of course consulting on site and custom developments meeting your special requirements.

KLINGER KGS/VD

The seal registered for patent approval compensates oblique flange positions up to approx. 8°.

KLINGER Wall collars

The wall collar protects against humidity penetration in case of infiltration water or ground water.

KLINGER-KGS

The rubber-steel gaskets

Application areas are water, waste water, gas, air, acids, caustic solutions and hydrocarbons with low forces and relatively low temperatures.